



**DOMESTIC INSTANTANEOUS GAS WATER HEATER**

**USER'S MANUAL**

**MINI 12 BF ErP**

**Read the technical instruction before installing the appliance  
Read the user's instruction before lighting the appliance**

**Cod. 6328403 – 09/2017**

## ISO9001 Certified

Thank you for purchasing our gas water heater.

Read this Manual before installing and operating and keep for future reference.

### Contents

• Special Advice.....	2
• Features &Benefits.....	2
• Specifications.....	4
• Parts Name .....	7
• Installation.....	9
• Using Methods.....	14
• Safety Cautions.....	18
• Maintenance.....	21
• Trouble-Shooting Guidance .....	22
• Enclose.....	23
• Packaging and Accessories.....	23
• Electrical diagram.....	24
• Conversion instructions.....	25

## Special Advice

Read the technical instructions before installing the appliance.

Read the user's instructions before lighting the appliance.

The manufacturer or any danger resulted from installation and operations not bear responsibility for any danger resulted from installation and operations not in accordance to this manual.

When the outdoors temperature is less than 0°C, the residual water inside the heater must be drained after use.

## Features & Benefits

### ■ Micro-Computer Intelligent Control System

The core component of the gas water heater is micro-computer intelligent control system, which is one of today's most advanced mechatronic technology. The CPU chipset can analyze automatically and set the optimal working parameter rapidly according to different data such as the flowing water quantity, the pressure situation and the actual inlet water temperature.

### ■ Digital Control for Automatic Constant Temperature of Outlet Water

This function is to monitor the outlet water temperature by a temperature sensor and to transfer the information to the micro-computer, so that the micro-computer could adjust the gas and air supply quantity to guarantee the constant outlet water temperature according to the temperature set by the user and the actual inlet water temperature automatically.

### ■ Low Start-Up Water Pressure

The lowest start-up water pressure of this product could reach 0.02MPa(the minimum water rate is 2.5 L/min), so it could also be used in the residence area with low water pressure.

### ■ AI Artificial Intelligent Memory Function

The gas water heater could work with the temperature you set last time when you restart it, so that you do not need to set the temperature again, which is great experience of the idea of ergonomics.

### ■ Effective and Energy-Saving

This product has advanced technologies called Strengthened Combustion and Forced Combustion. These patents aim to make the best use of heat energy with high working efficiency.

### ■ **Set Temperature by Touch**

You could set the required temperature easily by touching the digital display. The setting temperature is from 35°C to 65°C, which can meet different water temperature requirements with easy operation.

### ■ **Multiple Safety Protection**

This product has safety protections includes self-check protection, flame-out protection, over-heat protection, accidental power-cut protection, fan breakdown protection, over electric load protection, electric leakage protection, over wind pressure protection, over temperature protection, timing protection etc.

### **Tips**

The above conclusion comes from the safety protection test under lab experimental conditions. It may be affected by the surroundings in actual using environment. Thus, please use the product in proper conditions rather than using it devastatingly.

## Specifications

Name	Domestic Gas Instantaneous Water Heater	
Model	MINI 12 BF ErP	
Nominal Heat Input(Hi)	24kW	
Max Flow Rate(rise 25°C)	12kg/min	
Appliance Type	C13	
Gas Type	2H-G20-20mbar/3B-G30-30mbar/3P-G31-37mbar	
Gas category	II2H3P / II2H3B/P	
Max water pressure	Pw=10bar	
Min water pressure	Pw=0.2bar	
Electrical power supply	220VAC,50Hz	
Electric power	33W	
Degree of electrical protection	IPX4	
Ignition method	Water Control Automatic Pules Ignition	
Destination country	GB-IE-DK-FI	
Pipe joint	Gas Inlet	G 1 / 2
	Cold Water Inlet	G 1 / 2
	Hot Water Outlet	G 1 / 2
Flue Duct Diameter	Ø60×Ø100mm	
<p>Warning:</p> <ul style="list-style-type: none"> <li>● Read the technical instructions before installing the appliance.</li> <li>● Read the use's instructions before lighting the appliance.</li> </ul>		
		

**Parts Name**

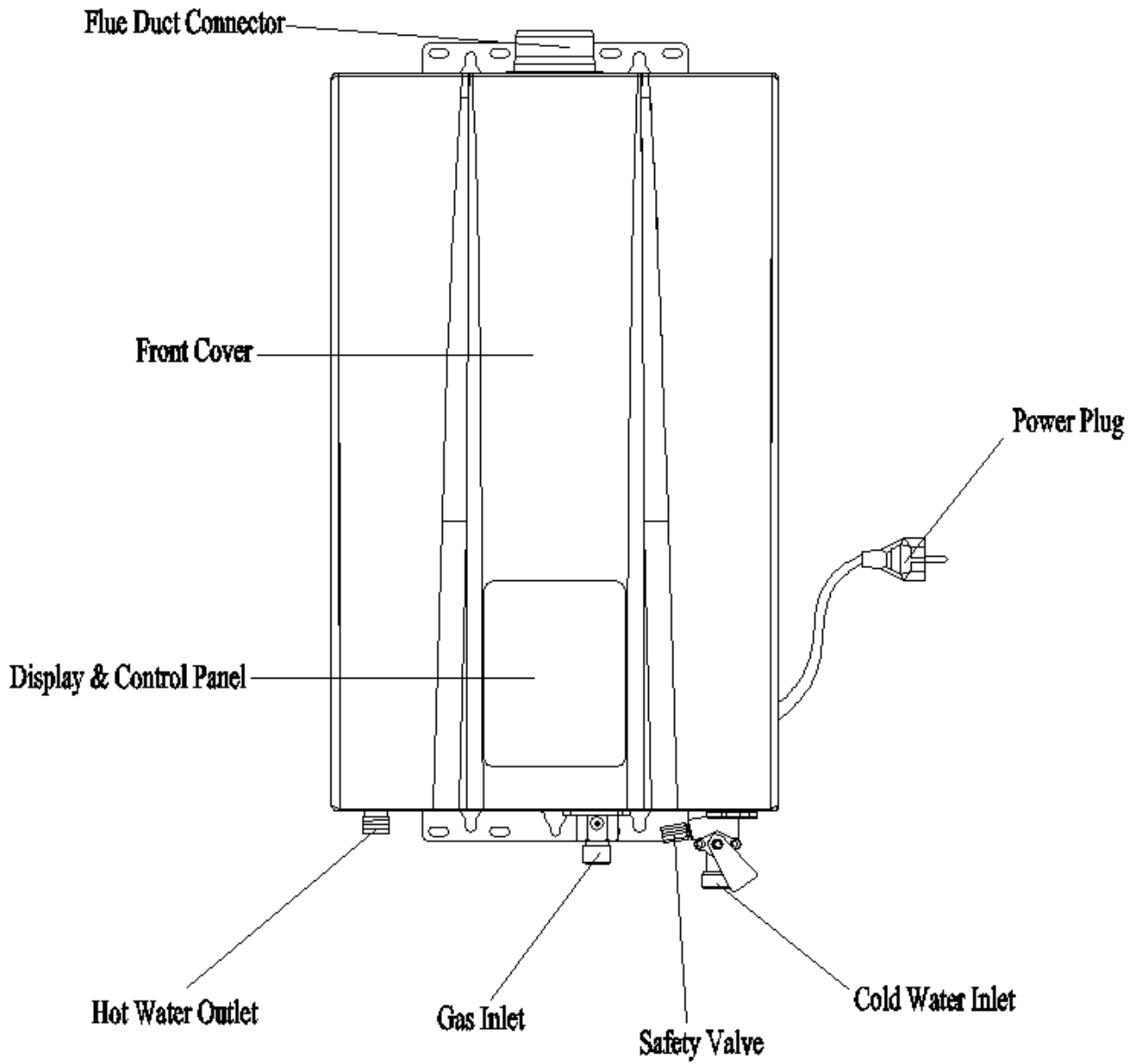

Fig. 1

(The dimension information is for reference only. Please refer to the actual product.)

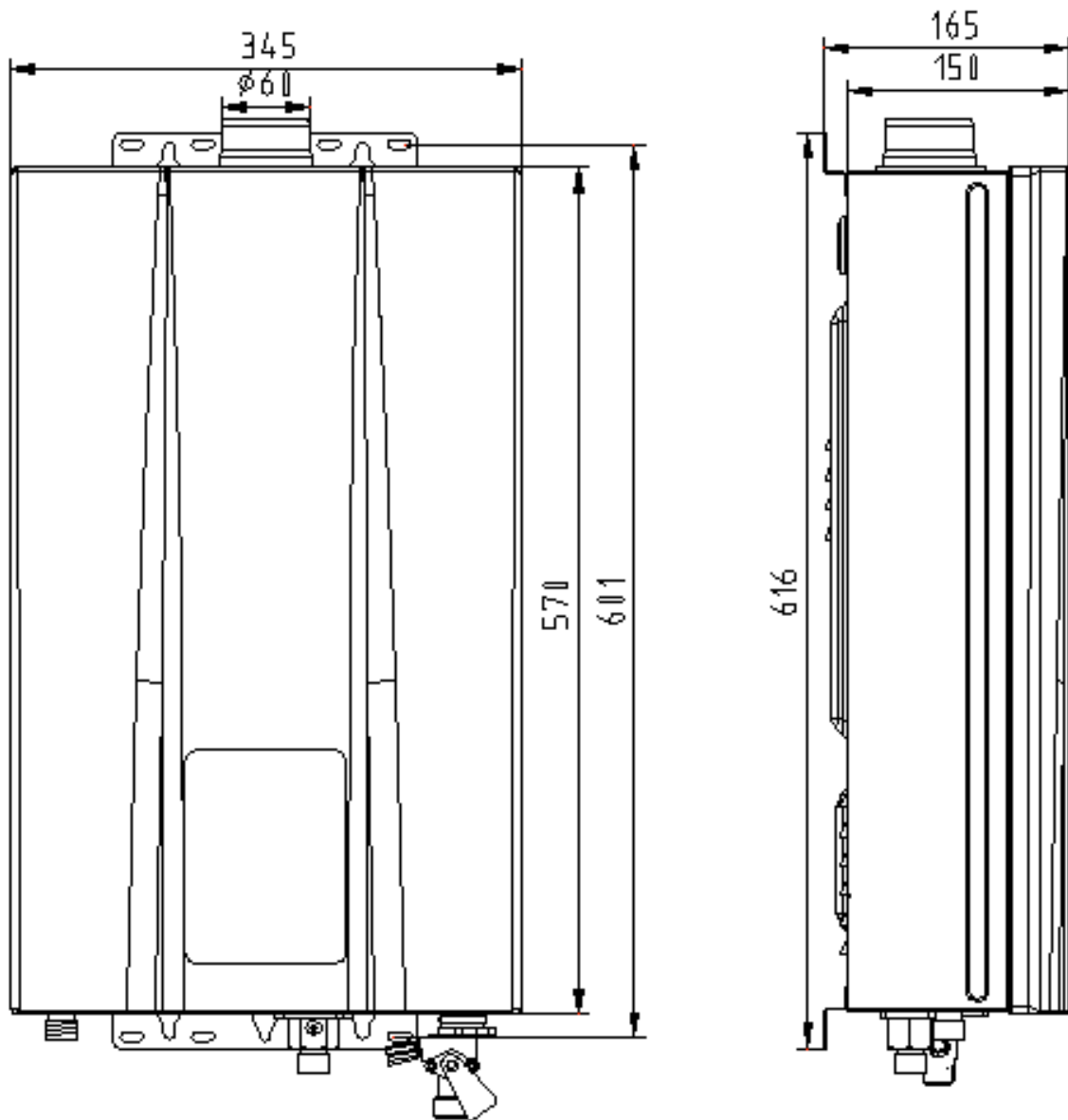

Fig. 2 (Unit: mm)

(The dimension information is for reference only. Please refer to the actual product.)

## Installation

Contact your local gas dealers or gas management department for a qualified engineer to install the gas water heater (users are recommended not to install by themselves). The installer should be called on to install and adjust the appliance, where appropriate.

This product is prohibited to use this gas water heater when flue pipe has not been installed correctly according to instructions.

### ■ Installation Requirements

- The flue of the gas water heater should be installed through an external wall, the heater cannot be installed in outdoors. (Fig.3)

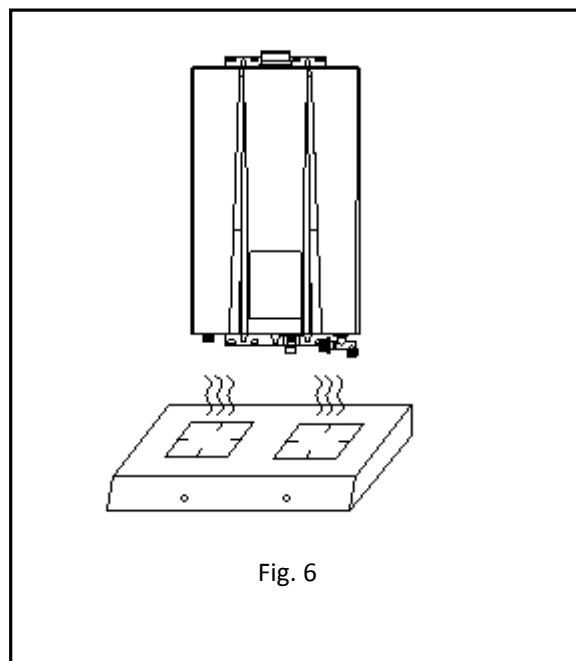
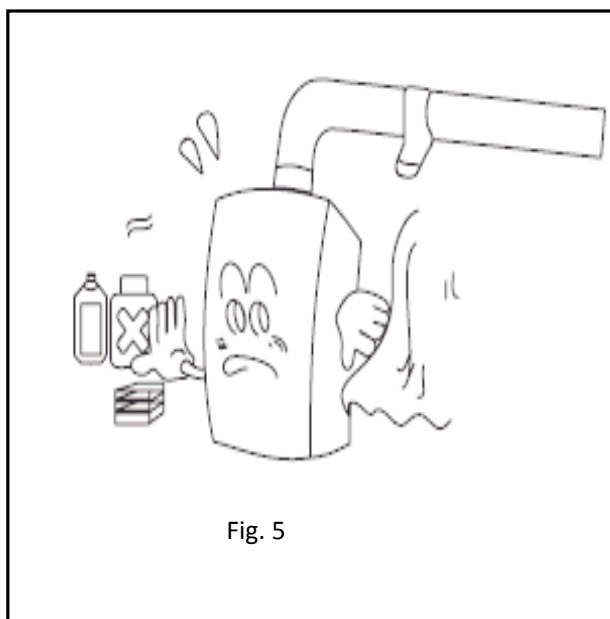
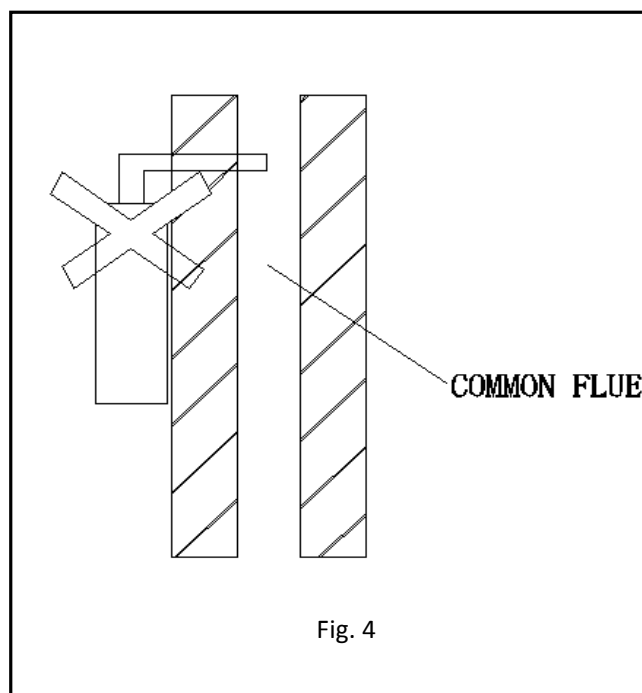
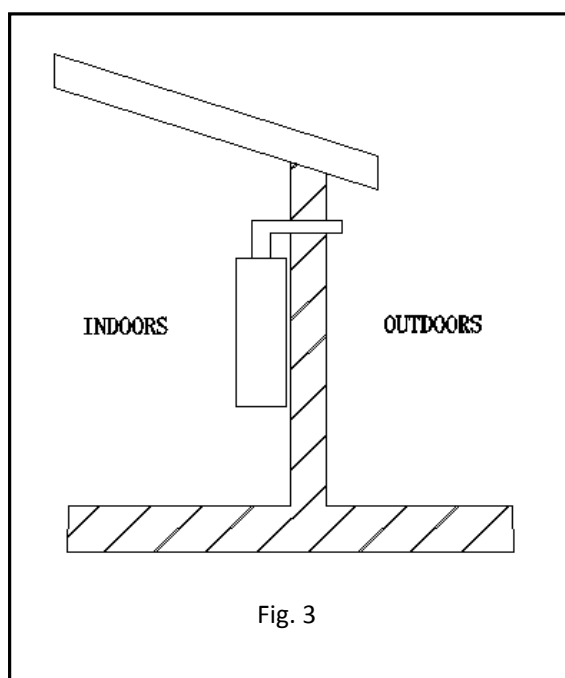



- The gas water heater installed in a suitably ventilated room , in accordance with the regulations in force.. It is not allowed to install in the bedroom, underground, bathroom or any other places with poor ventilation. (For B23 type)
- The flue of the heater cannot be connected to a common flue (Fig. 4).
- Please don't install the heater in places where special chemicals are used, such as the laundries or factories etc., otherwise it may cause rusting, shorten the lifetime of the heater, or prevent normal working. (Fig. 5)
- Don't install the heater above the gas stoves or other heat sources. (Fig. 6)
- The gas water heater should be kept away from the combustible materials with the distance shown in Fig. 7 at least.
- When the installation parts' materials are combustible or flammable should be used frame-proof board to isolate, heat-resistant plate and wall gap should be greater than 10mm, and the size of heat plate should be larger than water heater shell for 10mm. (Fig. 8)

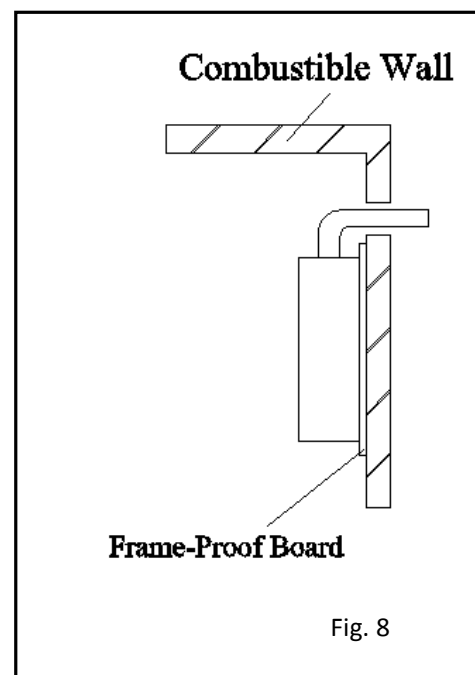
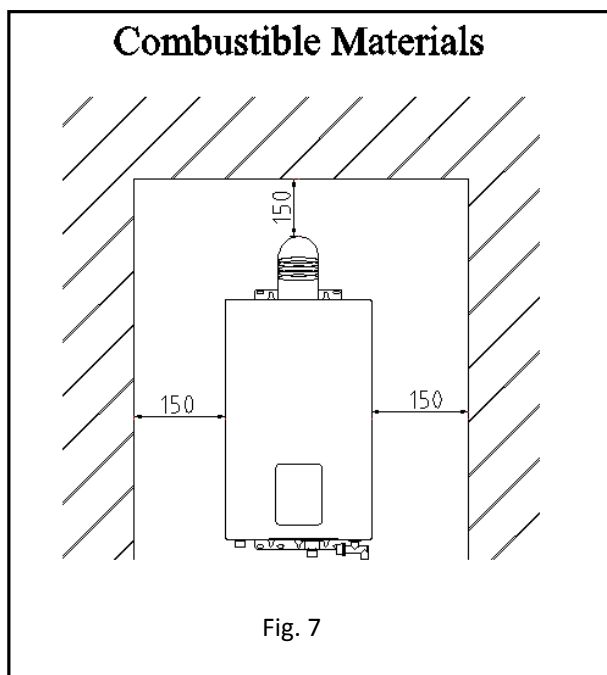

- The electric wires and electric equipment are not allowed to be placed on the top of the gas water heater. The horizontal distance between the gas water heater and other electric equipment should be more than 400mm.
- The power socket must have a reliable ground wire to improve safety. In order to reduce the number of times of plugging, it is better to use a socket with a switch. Whenever the water heater finishes working, please switch it off to avoid being electrified in a long term. The power supply socket should not be installed in the moist environment.
- The socket should be installed at the side of the product, and never be installed below the machine or the place with splashes, near the heat source, in exposure to sun and rain, or the place where it is not easy to control.
- The installation place of socket must be far away from the spraying space, so as to avoid

spraying the socket during shower.

## ■ Installation Method

### 1. Installation of Gas Water Heater

Drill holes in the wall according to Fig. 9, put an expansion bolt into the upper hole and plastic gasket into the lower hole, mount the water heater vertically on the upper bolt without inclination and tighten the lower holes with expansion bolts.

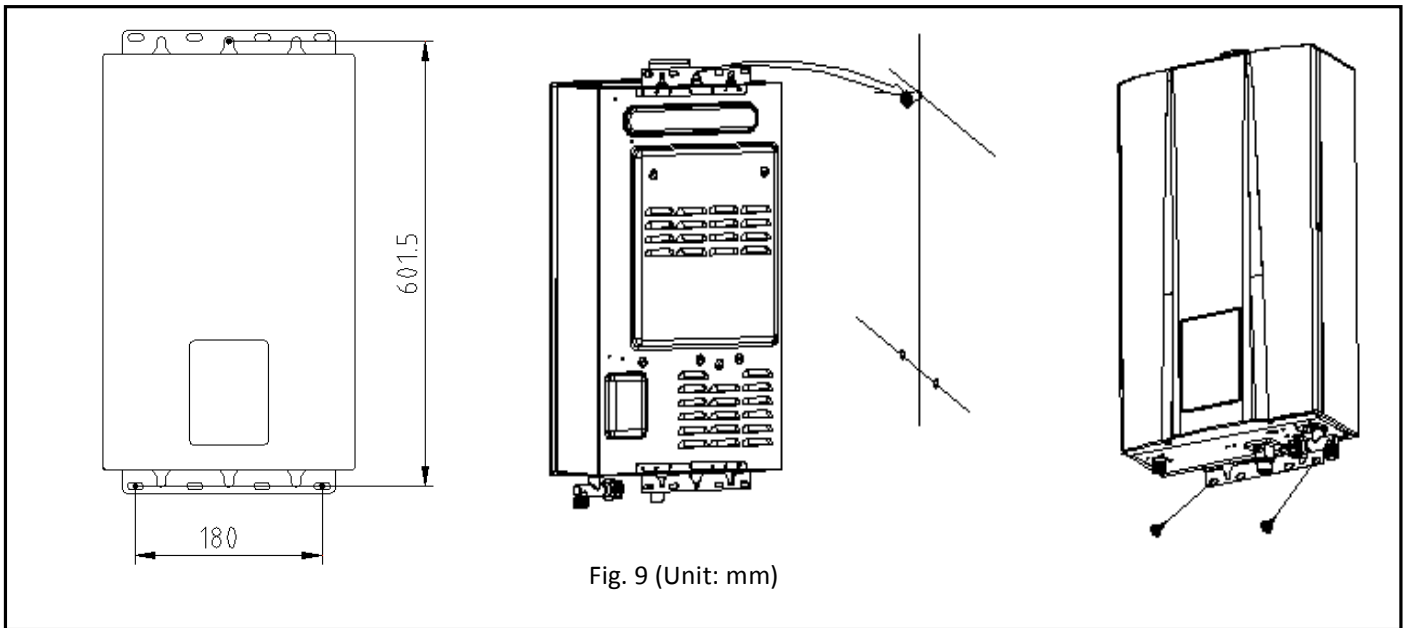

### 2. Installation of water and gas pipes (Fig. 10)

- It can be used when the flue system can ensure that the provided gas pressure can reach the lowest requirement. If gas water heater reaches the rated heat input, the gas pressure must reach the rated heat input in the technologic parameter form.

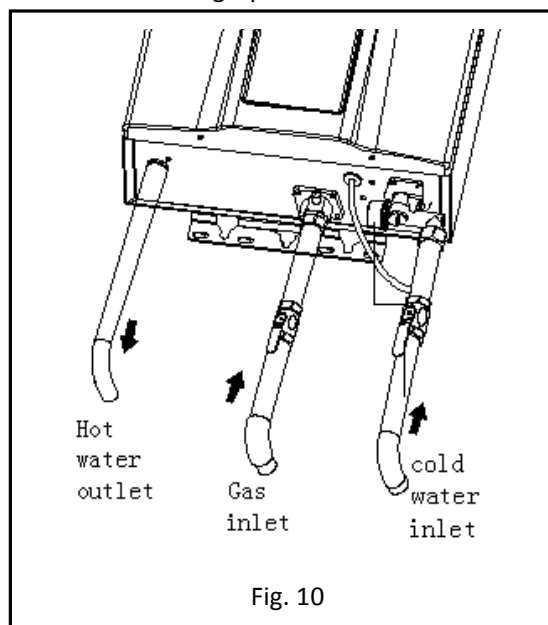

- Gas inlet

(1) Before connecting the gas supply, check the rating plate on the left side of the right front cover to be sure that the heater is rated for the same gas to which it will be connected.

(2) All such pipe shall be either new or previously used for no other purpose than conveying gas; and must be in good condition and free from internal obstructions. Burred ends shall be reamed to the full bore of the pipe. All fittings used shall be of malleable iron, yellow brass, or approved plastic fittings.

(3) When your connections are made, check for gas leaks at all joints (this includes all existing piping). Apply soapy water to all gas fittings and gas valve. **Soap bubbles are a sign of a leak.**

**NOTE:** No substance other than air, carbon dioxide or nitrogen can be introduced into the gas piping.

**NOTE:** If you have a leak, shut off the gas. After verifying the leak, tighten appropriate fittings to stop leak. Turn the gas on and check again with a soapy solution. **Never test for gas leaks using a match or flame.**

- Cold water inlet

(1) When facing the heater, the cold water inlet is on your right and the hot water outlet is on your left. Although water piping throughout your structure may be other than copper, we recommend that copper piping be used for at least 0.92 m before and after the heater (follow local codes). Keep water inlet pipe to no less than 1/2" diameter to allow the full flow capacity.

(2) Remember that water pressure must be sufficient to activate the heater when drawing hot water from the top floor. If the hot and cold connections to the heater are reversed, the heater will not function. 1/2" Copper or brass fittings work best when connected to the connectors. The flexible type connectors will make installation easier and seals to the water valve by means of a union connection with a washer type gasket at the joint. No pipe dope or thread tape is to be used at this joint. Be certain there are no loose particles or dirt in the piping. (Fig. 10)

(3) Water pressure must be sufficient to activate the water heater, the maximum pressure for the appliance is 10bar, even with the effects of water dilation, the water pressure in the appliance shall not exceed this value.

- Hot water outlet

Use a flexible or rigid pipe to connect with the sprayer without valve. If a valve or switch is connected to the sprayer, the outlet pipe shall not use heat and pressure unendurable material such as plastics, aluminum pipes, so as to avoid the pipe from breaking and scalding the user.

### 3. Installation of the flue:

#### • Flue Duct Installation of Forced-Exhausted Gas Water Heater (B<sub>23</sub> type)

This product is forced exhaust type gas water heater; it can be used only after the flue duct is installed according to the requirements strictly and can exhaust the waste gas to the outdoor area. It's not allowed to use the gas water heater without installing the flue duct correctly.

Please follow the below requirements during the installation of flue duct:

- (1) Please use the flue supplied by our company, referring to Fig. 11 about the installation method. If the flue duct is too short, you can extend it aptly. Check the flue duct and see if there is any damage or leakage every half a year.
- (2) The length of the flue duct should be less than 3m, and the number of elbows should not be more than 3 (one elbow equivalent 1m straight pipe).
- (3) The horizontal distance of the flue duct is the shorter the better. The flue duct end should have a 2° downward inclination (Fig. 11), so as to let the condensing water flows out.
- (4) The distance between the flue duct and the combustibile materials should be more than 150mm. If the flue duct needs to get through the combustibile materials or wall, it should use the heat shield material to pack the flue duct with the thickness over 20mm. (Refer to Fig. 7)
- (5) No cement between the flue duct and wall for the convenience of maintenance.
- (6) The flue duct should be fixed tightly. The connection part could use self-adhesive foil to avoid the waste gas going back into the room.

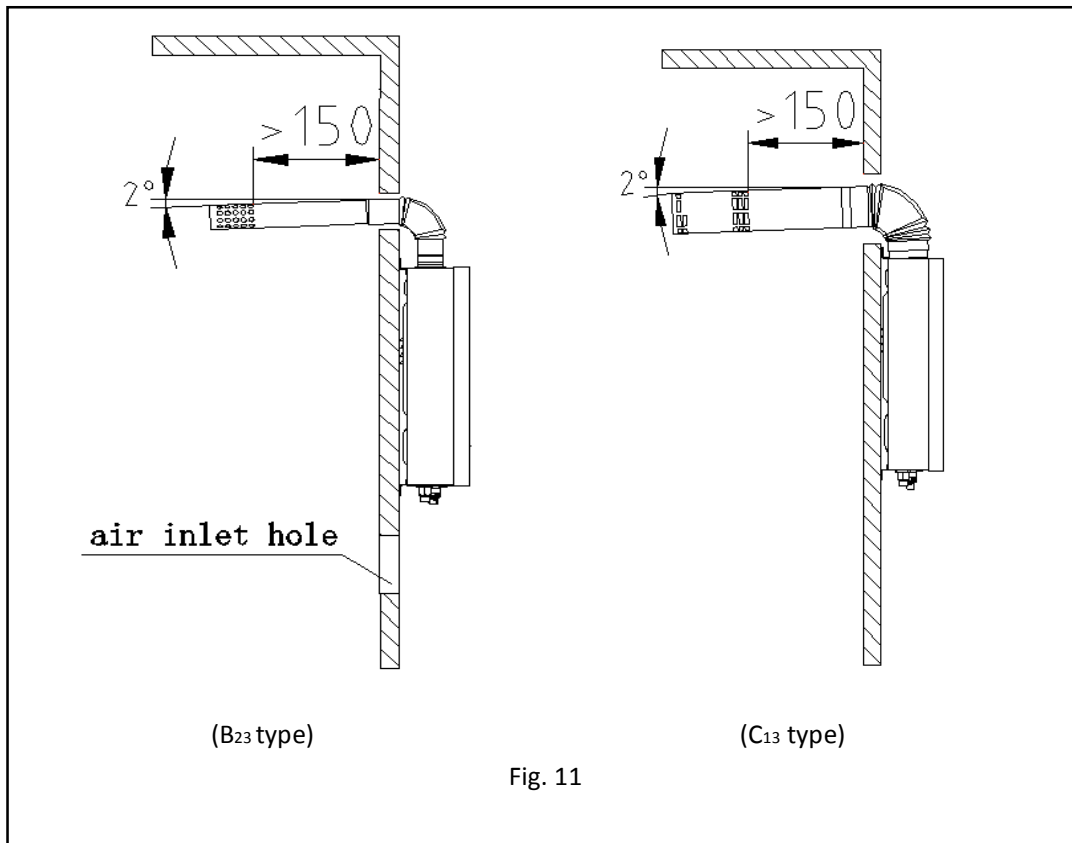

#### • Flue Duct Installation of Forced Exhaust & Air-Supply Type Gas Water Heater (C<sub>13</sub> type)

This product is a Forced Exhaust & Air-Supply Type gas water heater, it can be used before exhausting the waste gas to the outdoor according to the strictest requirements. It's not allowed to use the gas water heater without operating the flue correctly.

Please follow the below requirements during the installation of flue duct:

(1) Please use the flue supplied by our company, referring to Fig. 11 about the installation method. If the flue duct is too short, you can extend it aptly. Check the flue duct and see if there is any damage or leakage every half a year. Install the flue after the heater body is fixed. First, put the fixed flue through the hole in the wall, then insert the elbow into the exhaust outlet of the heater smoothly, the flue end should have a 2° downward inclination (Fig. 11), otherwise the rain may flow into the heater and damage it.

(2) The length of the flue duct should be less than 3m, and the number of elbows should not be more than 3 ( one elbow equivalent 1m straight pipe).

(3) The distance between the flue duct and the combustible materials should be more than 150mm. If the flue duct needs to get through the combustible materials or wall, it should use the heat shield material to pack the flue duct with the thickness over 20mm. ( Refer to Fig.7 )

(4) No cement between the flue duct and wall for the convenience of maintenance.

(5) The flue duct should be fixed tightly. The connection part could use self-adhesive foil to avoid the waste gas going back into the room.

### Cautions for flue installation

- Please use the flue supplied by our company, Other flues with different specifications are strictly prohibited. Do not change the specification of the flue.
- The installation of the flue must be correct, otherwise the waste gases will flow back and be dangerous.( Fig. 12)





w rong installation	problem caused	correct installation
	exhaust gas leak into room	
	abnorm al com bustion	
	w ork abnorm ally	

Fig. 12

## Using Methods

1. Display Function instruction
  - Display content instruction

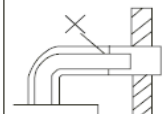
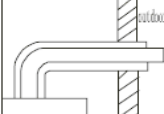

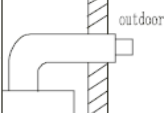
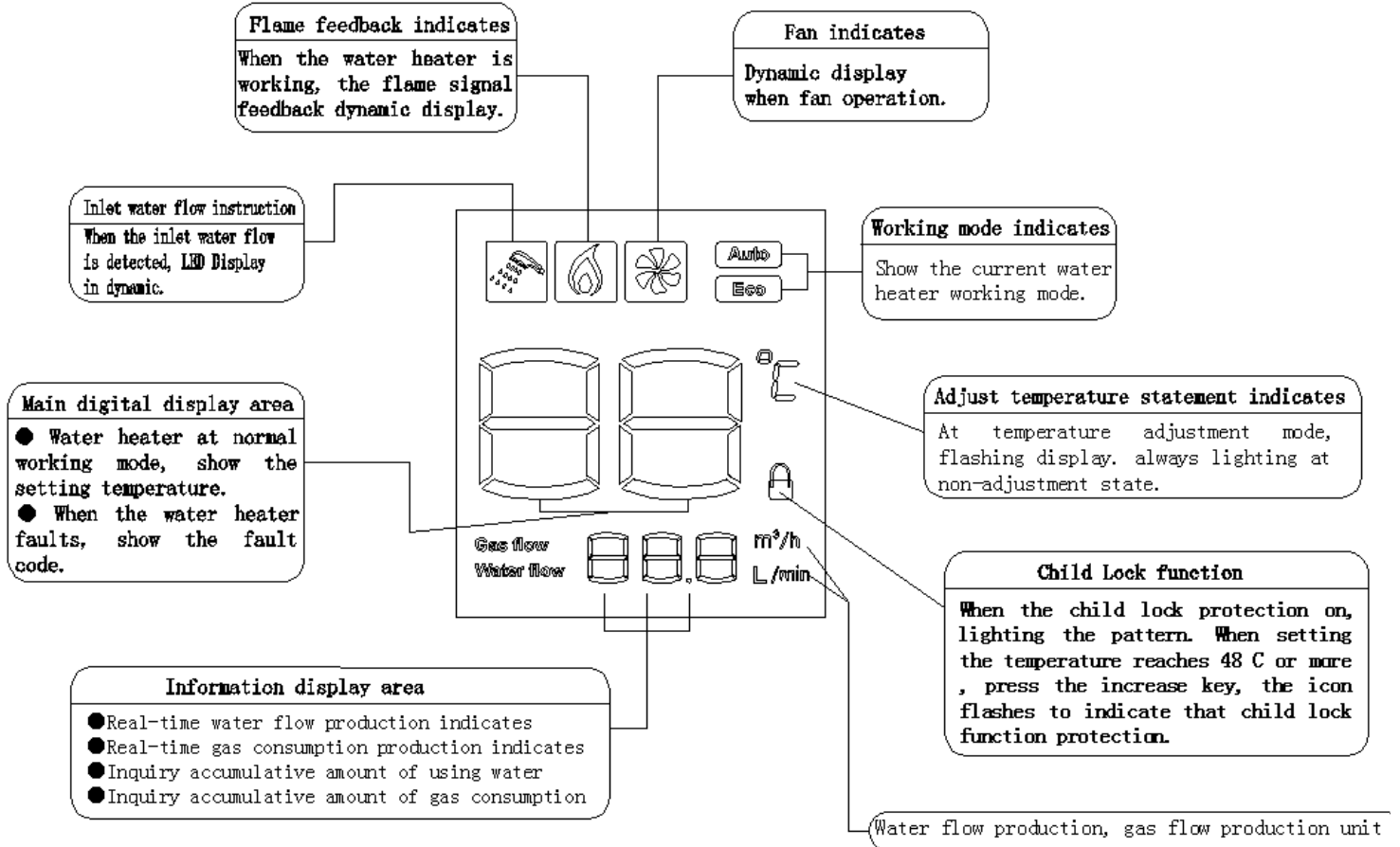

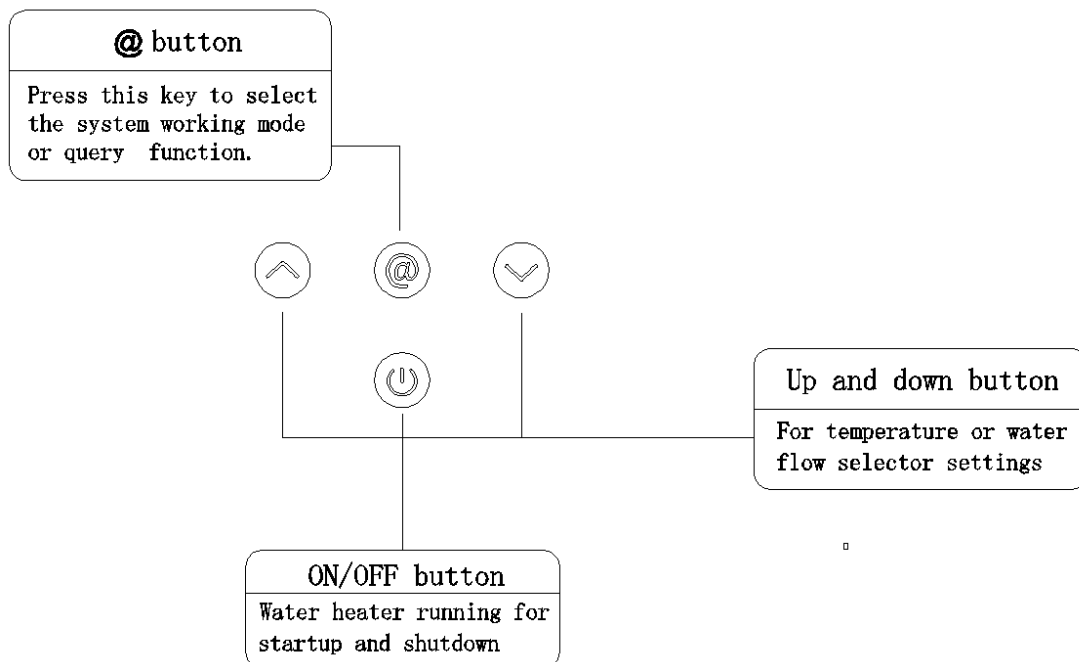
- Touch button instructions



## 2. Preparation before ignition

- Make sure that the gas used is in accordance with the gas stipulated in the label.
- Insert the plug, and then switch on the power. (The buzzer sounds “bi”)
- Turn on the gas valve.

## 3. Temperature Setting

- Press the “  ” (on/off) key on the control panel, the screen display and the designed hot water temperature. Press Up “  ” or Down “  ” to set the hot water temperature as desired. The lowest hot water temperature of this product is 35°C, highest is 65°C.

35 ~ 48 °C each time you press the button to change 1 °C, 48~65°C each time you press the button to change 5 °C ( that is 48°C、50°C、55°C、60°C、65°C), Each time you press the buzzer sounds.

## 4. Ignition & Water Outlet

- Open the water valve, there will be spraying signal shown on the screen. When the fan whirls, the igniter turns on and flame shows, hot water will come out accordingly. The display shows the setting temperature of outlet water.
- When using, water outlet flow and temperature can be adjusted in the same method as mentioned. After opening water and starting, Setting the range of 35-48 °C, Above 48 °C, only press down key(Child lock function to prevent burns). If want to set the temperature higher than 48 °C, turn off the hot water faucet and then press the button to warming.
- When the water valve is open, but the switch stays at OFF position, the water heater will stop working, and only cold water runs out. If hot water is needed, you should press ON button.
- Turn off the water valve and water heater stops working, but the fan still blows the combustion chamber for several seconds. The machine will show the temperature set last time when opening the water valve next time.

### **Attention:**

- ▲ If the water valve is open before the water heater is switched on, the gas water heater will into the protective mode, and the buzzer sounds. Please close the water valve then.
- ▲ It might take several trial ignitions after installation or the first use after recharging the gas tank to push out all the air remained in the gas pipe.
- ▲ The temperature shown on the screen is the setting temperature, while the outlet water temperature differs according to the length of pipes and different seasons. Therefore, please refer to the actual outlet water temperature.
- ▲ If hot water flow excesses the water heater’s capacity, the water may not be hot enough. Please turn down the water flow accordingly
- ▲ Every time the water heater starts working, please pay attention to the setting temperature on the display and be careful not to being scaled.
- ▲ In order to avoid being scaled, whenever using the water heater, you must test the water temperature with your hand before showing.
- ▲ When the gas water stops working and the display shows error codes, please close the water valve and reopen. Or press the on/off button until the machine is off, and then restart it. If the water heater still cannot operate regularly, please turn off the gas valve and cut the power, recharge the machine and ignite again after a few minutes.

## 5. Use function mode

In standby mode (ie, no water status), press the function (@) key, you can select "Auto", "Eco", "normal" three modes in turns, they can cycle, the system default normal mode.

Three types of function mode instruction

- Normal mode (default): According to the user to set automatic temperature thermostat, then "Auto", "Eco" display lights are not bright.
- Auto mode: ("Auto" display lights is bright.) According to the inlet water temperature, the system automatically adjusts the setting temperature (as shown in Table 1), allowing users to get the most comfortable hot water supply in anytime.

Table 1 Temperature mapping table

No.	Local Water Temperature	Corresponding Temperature
1	$\leq 15^{\circ}\text{C}$	$45^{\circ}\text{C}$
2	$16^{\circ}\text{C}-21^{\circ}\text{C}$	$43^{\circ}\text{C}$
3	$22^{\circ}\text{C}-27^{\circ}\text{C}$	$40^{\circ}\text{C}$
4	$\geq 28^{\circ}\text{C}$	$38^{\circ}\text{C}$

Note: Under the Auto mode, after the heater switch-on, the temperature displayed is the one set before the heater starts to work. The temperature will not change according to the local water temperature change after the heater starts to work.

- Eco mode: ("Eco" display lights is bright.) In the state of saving mode, after calculation by microcomputer, automatically adjust the amount of gas supply, compared other modes more economical by water heater gas consumption, not only save gas, but also can guarantee a constant water temperature to meet the requirements of users.

In the state of saving mode, the user can freely select the desired of setting water temperature, the user presses the up or down keys to adjust the setting temperature does not exit the power saving mode, in this case the user needs in the standby mode press the function key again to exit the power-saving mode.

## 6. Instant hot water production and real-time air consumption display

When the water heater in working condition, the display will take turns showing the current real-time hot water production and real-time gas consumption, the figures will be changed accord the actual working conditions, so that users can understand the water heater current working conditions.

For example: When the real-time information display "12.0 L / min", indicates that current real-time hot water production by water heater per minute 12 L. When the real-time information display "2.0m<sup>3</sup>/h", indicates that current real-time gas consumption by water heater per hour 2.0m<sup>3</sup>

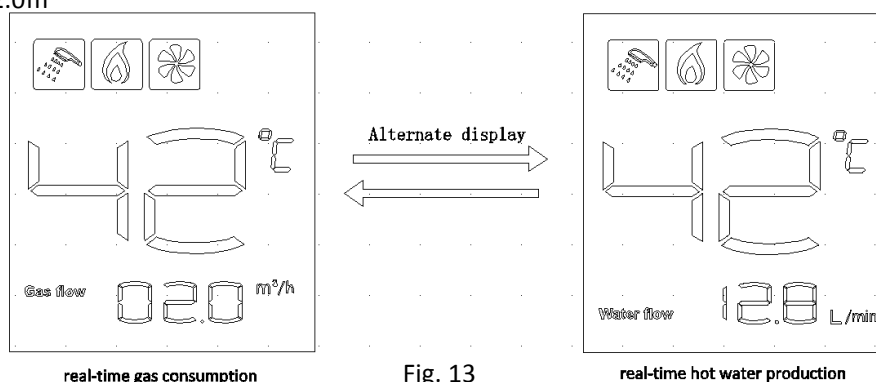

Fig. 13



## 6. Inquiry the cumulative amount of gas and water

In working statement, @ buttons can inquire about the cumulative water consumption and gas consumption. Click the @ key to query cumulative amount of using water information, press @ key again can be inquired accumulated gas consumption information. Press the third time for the @ button or no operation for 20s, can exit the inquiry function.

Note:

- Real-time gas consumption show the basic unit of  $\text{m}^3/\text{h}$
- Real-time hot water production show the basic unit of L/min
- Cumulative amount of using water and gas consumption show the basic unit of  $\text{m}^3$ , When the display numbers reach  $999\text{m}^3$ , water record is automatically cleared. For example, when the query information display "Water production  $180\text{m}^3$ ", represents a total cumulative amount of water heater  $180\text{m}^3$ . When real-time gas consumption information shows "volume  $8.3\text{m}^3$ ", it indicates the water heater cumulative total gas consumption  $8.3\text{m}^3$ .
- Cumulative gas consumption and cumulative amount of water is automatically cleared after power failure
- The contents of the query function display only for reference, can not be used for measurement.

## Safety Cautions

### ■ Prevention of freezing water

Drain the residual water inside the heater to prevent frozing water after every use when the environment temperature is near or under  $0^{\circ}\text{C}$ , do as instructed (Fig. 14)

- Close down the gas valve 1
- Turn the water temperature knob 2 to "low" position, or turn the water volume button knob to "large" position (level).

- Close down the cold water valve sans 3, if a valve is installed on the hot water circuit, open it.
- If there is a control valve 4 at the hot water outlet, please open it.
- Turn the drain valve 5 and take off, replace it after the residual water is completely discharged.

Fig.14

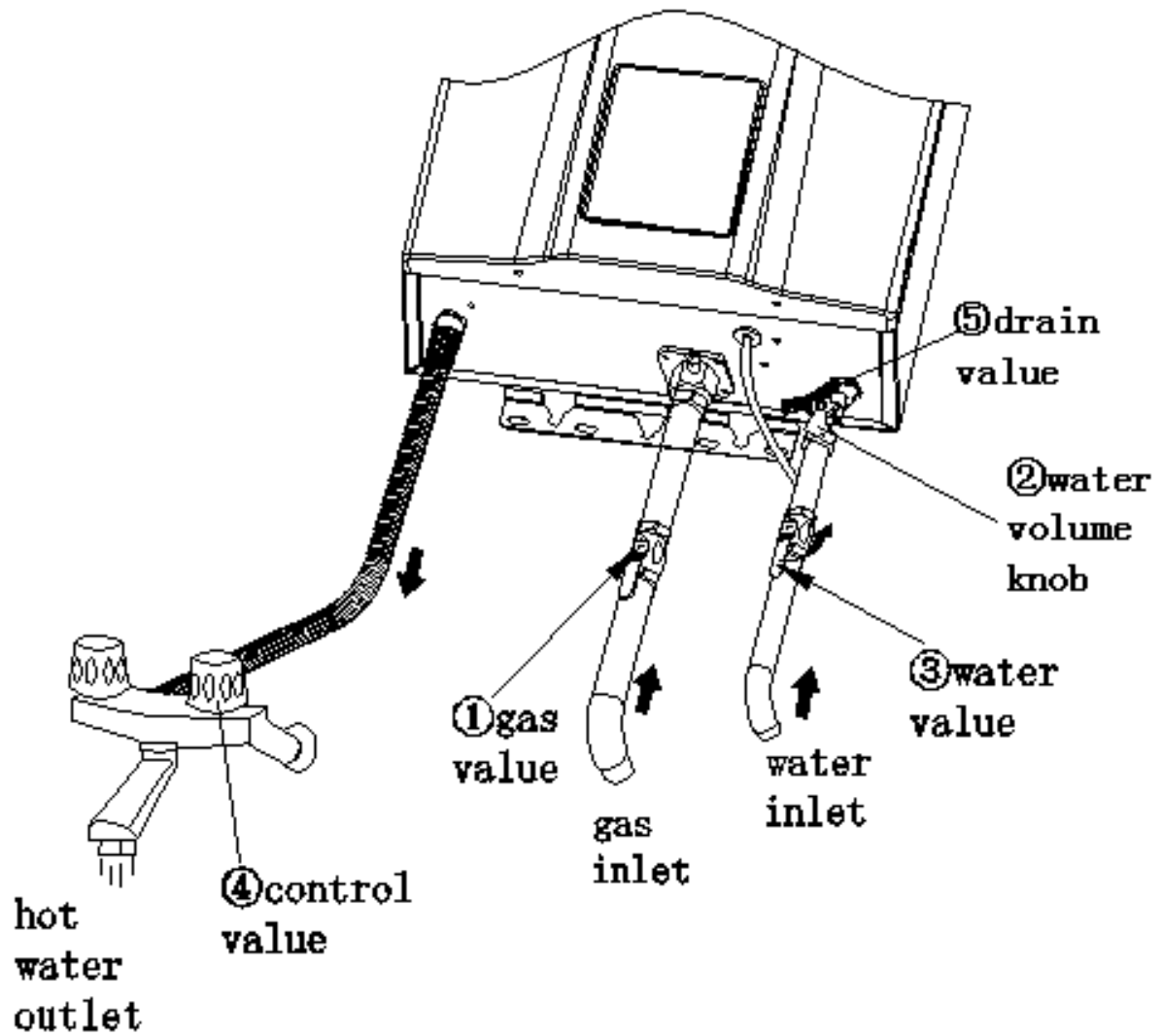

■ Gas accident prevention

- Check if the flame of burner is out after use and do not forget to turn off the gas valve (Fig. 15) and power.
- Always check the gas connectors for gas leakage with soapsuds. If any gas leakage is detected, open the room windows and doors. At that moment, do not ignite or operate the switch of electric appliances or plugs because the flame or electric spark can result in explosive accidents. (Fig. 16)
- Heaters must use the gas type which the heater is designed to use, different type of gas or the same gas in different place must not be used.
- Always check the gas pipe and change the pipe every year to avoid gas leakage due to cracking.
- If the flame goes unsteadily, stop using the water heater and contact the qualified service facility for repair or adjustment.

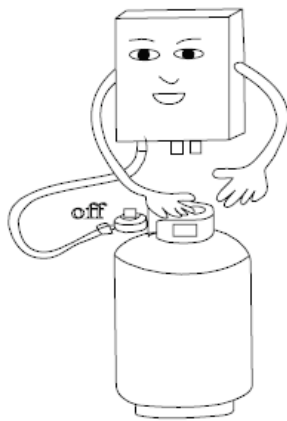

Turn off gas after use.

Fig. 15

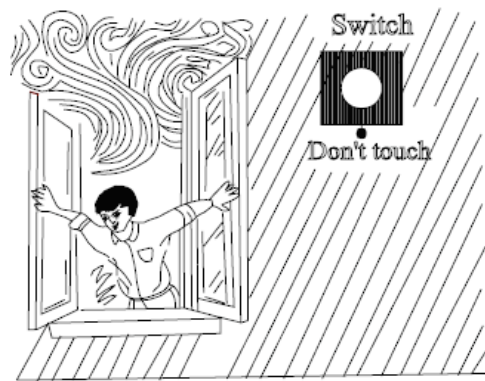

Open the window in case smelling

Fig.16

■ Fire prevention

- Do not leave the water heater unattended whilst still in operation.
- In case of power failure or water failure, turn off the gas valve and water inlet valve.
- Do not place towels or clothes on top of the water heater. (Fig. 17)
- Do not store inflammables, explosives or volatiles near the water heater. (Fig. 18)
- Never incline the gas tank or turn it upside down, the fluid gas is easy to flow into the heater and cause fires.

Do not hang thing on or overhead

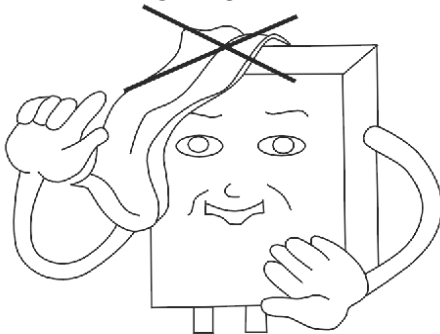

Fig.17

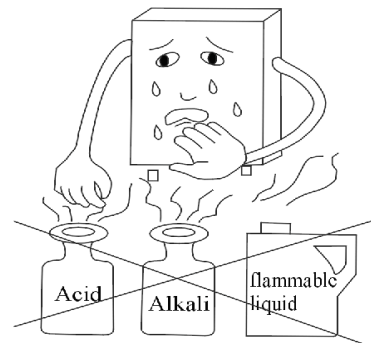

Fig.18

■ Carbon Monoxide toxicosis prevention

- This product must exhaust the waste gas to the outdoor area during working, so the flue duct must be connected to the joint on the top of the water heater to exhaust the waste gas out to the outdoor area, keep the air fresh indoor and avoid incomplete combustion. Otherwise, it will cause danger or even death.
- Too low or too high gas pressure leads to abnormal combustion. At that moment, stop using the water heater and get in contact with a service engineer.
- Dust and accelerated carbon would block the heat exchanger due to long time use, and affect the combustion performance, causing the Carbon monoxide to increase. Therefore, contact a qualified person to clean and clear the dust and accelerated carbon every half year to ensure the combustion product discharges smoothly.
- The heater must be installed vertically, if inclined it will make the flame touch the heat exchanger and cause the monoxide to increase.

■ Don't drink the heater water

The water in the heater is not suitable for drinking.

6.Handle with abnormal conditions

If there is abnormal burning (flame light-back, flame lift, yellow tip or black smoke, etc), smell or noise, or other emergent situations, keep calm and shut off the gas supply valve and power switch, and contact the service facility or gas dealers for repair or adjustment.

■ Scald prevention

- When using the heater discontinuously, be careful not to be scalded by the over high temperature hot water at the start and stop times.
- During use and immediately after, do not touch any places especially the surround of the flame Check window or the front cover except for the knob and control panel in order to avoid scalding.



**WARNING: Forbid any interference with a sealed component, a fire or explosion may result causing property damage, personal injury or loss of life.**

## Maintenance

- ▲ The appliances should be checked and maintained periodically by a competent person
- ▲ Check the gas tube/pipe regularly for any defect. Contact service center for any doubt.  
Always check the gas pipe for cracks.
- ▲ Always check for leaking water.
- ▲ Ask qualified technicians to examine the burner, flue and fan once a year.
- ▲ Always check the flame inside the water heater for any abnormal conditions.
- ▲ Keep the cover of the water heater clean.
- ▲ This product uses water pressure to open the channels. When the water pressure is lower than 0.2bar, the heater cannot be ignited.
- ▲ The drain valve is dripping. When the water pressure is too high, the drain valve will release the water so as to reduce the pressure to protect the heater.
- ▲ When the heater is supplying hot water to several points at the same time, the hot water flow would be reduced, or no hot water will issue at all.
- ▲ When the temperature outside is too low and the exhausted gas meets the cold air, it will be condense as white fog. This is normal.
- ▲ When the water temperature is too high, set to a lower temperature and reduce the water tap. If the water temperature outlet is too high, please open the tap to reduce the temperature.
- ▲ When the water temperature is too low, and the hot water volume is so high so that it exceeds the heater's heating power, the outlet water will be not hot enough, please reduce the water volume.
- ▲ In order to ignite immediately, the fan in the appliance will delay running for a long time and then stop automatically. This is normal.
- ▲ When you use the multi-function shower, the resistance may be too large, and the water inlet pressure will be too low or the water inlet volume will be too little (below the starting –up water volume), there may be flameout or can not be ignited, please choose the suitable shower function.
- ▲ The residual water in the heater may be frozen in the winter, this is bad for the heater, so you must drain the water after use. (Please refer to the drain methods.).
- ▲ In order not to create scaling, please close the gas valve after using the heater, let the hot water out of the appliance. When the outlet of the hot water is cold, close the cold water valve.

**Cleaning:** The water heater should be cleaned annually, keep the dust away from flue gas passageway. See the Cleaning Instructions below. (Only for service engineer)

- 1) Turn off power, shutoff gas supply;
- 2) Wait one hour to cool down water heater;
- 3) Remove the front cover, by taking out Cover Screw;
- 4) Using compressed air or equivalent to clean the area between the fins and the heat exchanger;
- 5) Do not unscrew or move any other parts of water heater;
- 6) After Cleaning, put the front cover back.

## Trouble-Shooting Guidance

Errors											Solutions	
Causes		Flame out while using	Non-ignition after opening the cold water valve	Deflagration after ignition	Yellow flame with smoke	Abnormal flame with strange smell	Ignition with strange sounds	Water still not hot, when turning to the high temperature position	Water too hot, when turning to the low temperature position	Flame out when turning to the low temperature position		Flame not out when the cold water valve is closed
Main gas valve off			•									Turn on the main gas valve widely or change new gas.
Main gas valve half on		•						•				Turn on the main gas valve widely
There is air in the gas pipe			•									Constantly continue to turn on the water supply control valve
Supply gas pressure inappropriate	High			•			•					Contact the technician to check the gas source pressure adjustment valve
	Low	•						•				
Main cold water valve off			•									Turn on the water supply main valve
Frozen			•									Reuse it until melting
Pressure of cold water too low		•	•							•		Contact the technicians to check water pressure
Adjust water temperature wrongly								•	•			Rotate the water flow adjustment rod appropriately
Air supply not enough		•				•						Improve air exchange, and let more fresh air in
External wind pressure too high		•	•	•								Stop using it
Burner assembly blocked					•	•	•					Contact after-sales services
Heat exchanger assembly blocked		•			•	•						The same as mentioned above
Errors in the water control device		•	•					•	•		•	The same as mentioned above

## Enclose: Explanation of the Error Codes

In the process of using, the display of the fire, wind and other patterns disappeared, because the security device has been caused by action. Display flashing fault code shows that the failure of its occurrence, the reason for the exception.

Fault code has been flashing when failure. On such occasions, please turn off the hot water valve and then open, or close / open the monitor, and then operate 1-2 times. If the display still show the fault code, please be sure to close the water valve and valve, unplug the power plug, and contact the after-sales service.

Error Code	Explanation
01	Inlet water temperature sensor breaks down
10	Detect a flame signal through pre-check
11	Ignition fails
12	Normal combustion flames out accidentally
13	Thermostat fault protection
32	Fan blocking protection
40	Fan or its drive circuit breaks down
50	Over high temperature protection (outlet > 80°C)
51	Over high temperature protection (inlet > 65°C)
60	Outlet water temperature sensor fault protection
80	Timing protection

## Packaging and Accessories

Description	Quantity
Gas water heater	1
Connector of gas inlet (with rubber seal ring)	1
Expansion screws	1
Mounting screws	2
User manual	1
Self-tapping screws	2
Flue duct (B23 type)	1

# Electrical diagram

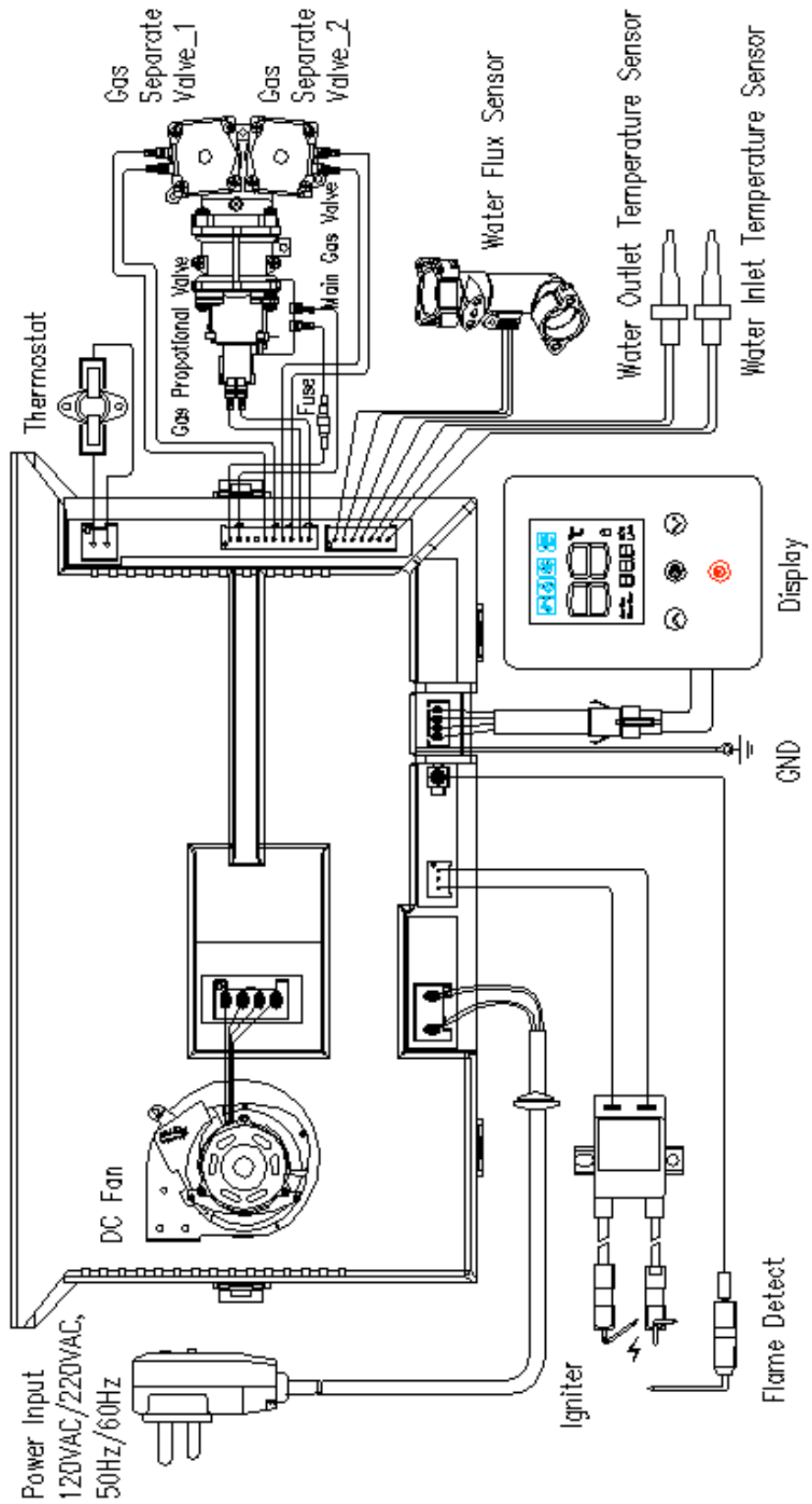

- If change, No special advice!



# Conversion instructions

pic 1

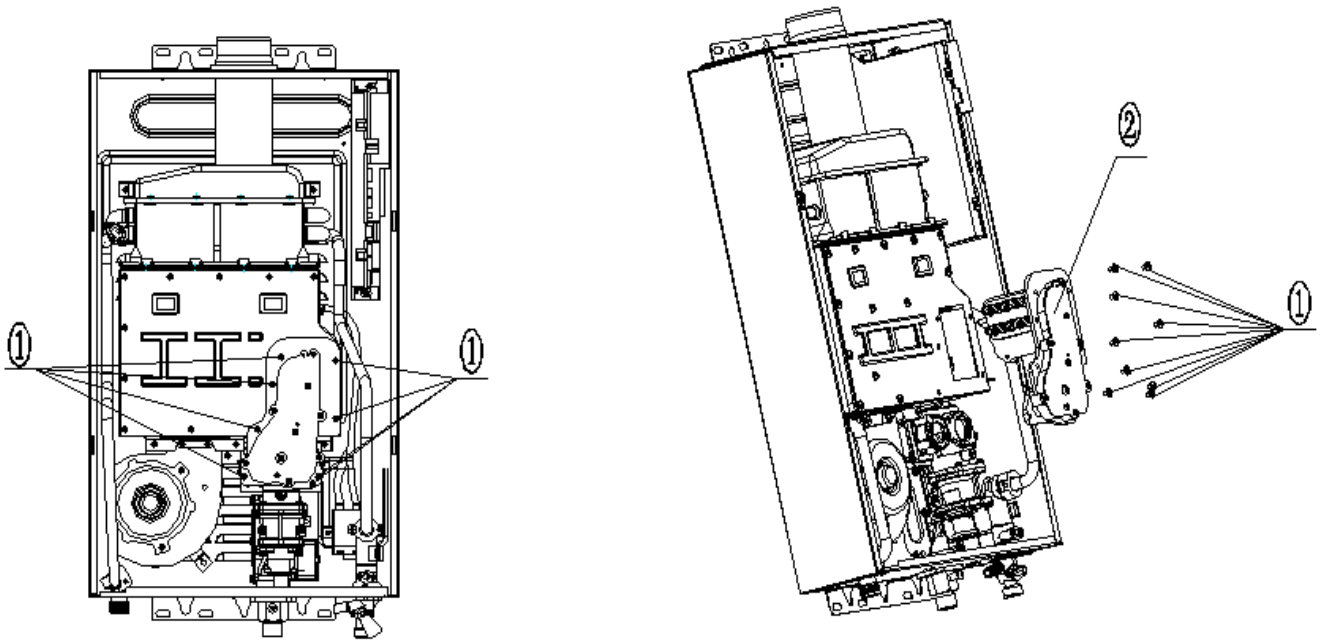

pic 2

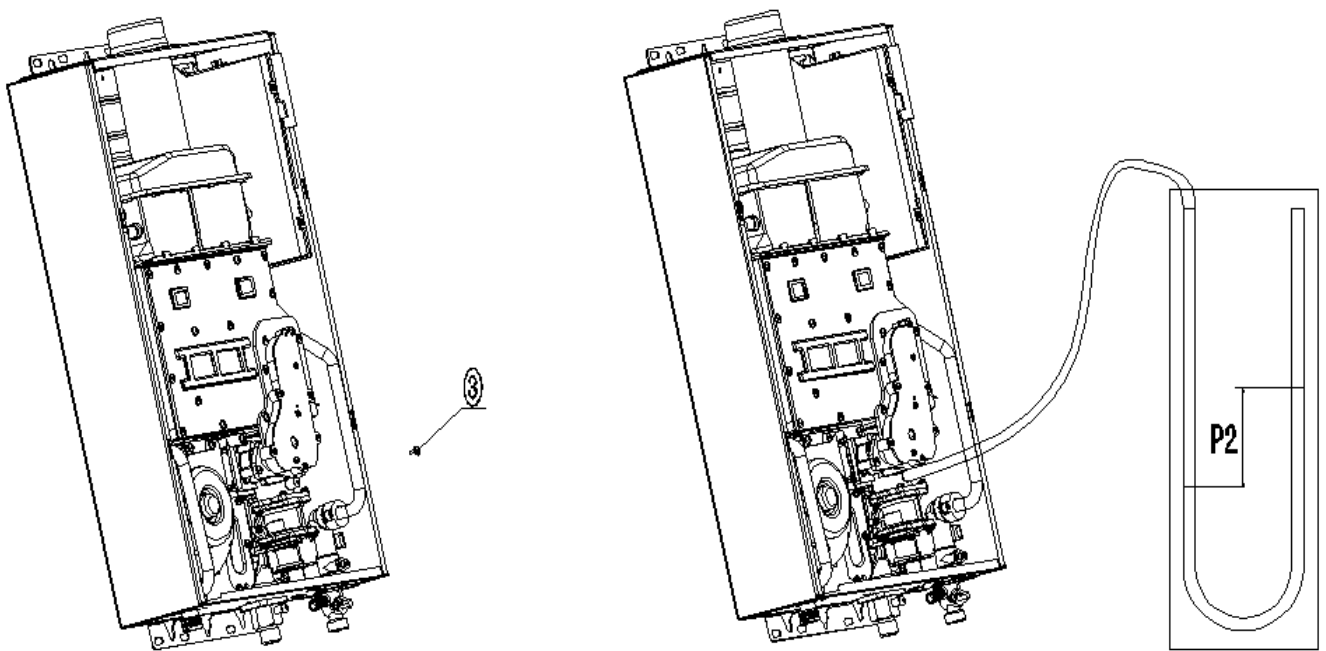

## Technical instruction

<p>Step 1 <b>Open front cover</b></p>	<p>1.Screw off the front panel and disconnect the display and control unit terminal.</p>
<p>Step 2 <b>Replace gas tube assembly</b> (pic 1)</p>	<p>1.Screw off the gas tube assembly① and take it out②. 2.Change to the matched gas ejector tube assembly. Note: It's necessary to examine the air tightness after change, to check the seal ring on the gas control system installed well to prevent gas leakage.</p>
<p>Step 3 <b>Setting the gas type, volume, and model</b></p>	<p>1.Connect display and control unit 2.Volume selection: Within 10s, after the system is powered on but switched off, press Up and Down keys together for 2s. After the buzzer rings once, "L" blinks on the display, which means that you have entered the volume selection mode. Press On/Off key to enable the adjustment function, and then Up or Down key to adjust the volume. Table 1 shows the volume parameter settings. 3.Gas type selection: After the gas volume is adjusted, press On/Off key to both confirm the modification and enter the next selection interface. The "q" that blinks on the display means that you have entered the gas type selection mode. Press On/Off key to enable the selection function, and then Up or Down key to select a gas type. The originally selected type is displayed the first time you press Up or Down key, which is 12T by default. Table 2 shows the gas type parameter settings. 4.Model selection: After gas type is selected, press On/Off key to both confirm the selection and enter the next selection interface. The "F" that blinks on the display means that you have entered the model selection mode. (It's the factory default and no need to select, just press on-off key to skip this step.)</p>
<p>Step 4 <b>Secondary pressure adjustment</b></p>	<p>1.After adjusting the volume and gas type, screw off the secondary pressure screw on the gas control system③. And connect the secondary port and U type barometer with rubber pipe. 2.After the system is switched on and it combusts normally, press Up and Down keys together for 5s. The "88" digital tube displays "26", which means that you have entered the secondary pressure adjustment mode. 3.Then press On/Off key. The high-order position of the "88" digital tube blinks, which means that you can now regulate the secondary pressure of the big endian by the Up or Down key. 4.Press On/Off key, the low-order position of the "88" digital tube blinks, which means that you can now adjust the secondary pressure of the little endian by the Up or Down key. 5.After the adjustment, press On/Off key to confirm and exit from the adjustment mode. 6.After the secondary pressure test compliant, mount the secondary pressure screw and conduct leakage test with fire. Note: After you modify the secondary pressure, wait for 2s or 3s to ensure that the system has recorded the updated the current value. You must verify the upper limit and then the lower limit before you exit. Table 3 shows the</p>

	secondary pressure of different gas type and volume.
Step 4 <b>Assemble front cover</b>	1. Check the airproof of finished product ensure no gas leakage. 2. Assemble front cover, tighten screws of front cover.
<b>Note</b>	1. When replace with new gas tube assembly, notice whether the seal ring on gas control system assembly is fixed well. 2. Check the airproof of finished product ensure no gas leakage. 3. After finish replacing the conversion kits, replace the corresponding labels on the appliance, for example, data plate. 4. This instruction is for reference only, take the material object as the standard.

### Replaced Part list

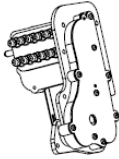
Replaced Part name	diagram	Gas type	Figure No.	Specification
Gas tube assembly		G20	JSQ13ST25_06B1	hole of $\Phi$ 0.86 hole of $\Phi$ 1.52
		G30 G31	JSQ13ST25_06B2	hole of $\Phi$ 0.74 hole of $\Phi$ 1.04

**Table 2.1 Volume parameter settings**

No.	Displayed Symbol	Parameter	Parameter Description
1	L	10	10L
2		11	11L
3		12	12L

**Table 2.2 Gas type parameter settings**

No.	Displayed Symbol	Parameter	Parameter Description
1	q	20	G20
2		30	G30
3		31	G31

**Table 3 the secondary pressure**

Gas type	Litre	P <sub>2</sub>	
		Max	Min
G20	10L	1020 ± 20Pa	250 ± 10Pa
	11L	1280 ± 20Pa	250 ± 10Pa
	12L	1430 ± 20Pa	250 ± 10Pa
G30	10L	1050 ± 20Pa	250 ± 10Pa
	11L	1280 ± 20Pa	250 ± 10Pa
	12L	1450 ± 20Pa	250 ± 10Pa
G31	10L	1310 ± 20Pa	250 ± 10Pa
	11L	1590 ± 20Pa	250 ± 10Pa
	12L	1890 ± 20Pa	250 ± 10Pa

▲Attention: Conversion to other gases shall be carried out by a qualified installer, as described in installation instructions



---

**Fonderie Sime S.p.A**

Via Garbo, 27 - 37045 Legnago (VR)

Telefono +39 0442 631111 - Fax +39 0442 631292

[www.sime.it](http://www.sime.it)